

ORWAK FLEX 4240

Compact general waste in 63 gal bins in our waste compactor FLEX 4240! It is a robust and reliable machine with a compact and lightweight design. Thanks to the small footprint, it takes up little floor space. The 4240 is easy, safe and convenient to use! The multiple-chamber unit offers a top-loading setup, while the single-chamber version is based on the principle "Roll in! Compact! Roll out!".



SAFETY



ORWAK BENEFITS



MORE PRODUCTIVE USE OF TIME

Less time spent on waste handling, more time for your core activities!

MORE SPACE & ORDER

Our balers rapidly minimize the space the waste takes up, keeping aisles free and tidy.

LESS COSTS, MORE VALUE

More compaction = less waste volume to transport. Fewer transports required results in lower transportation costs and reduced CO₂ emissions. Sorting at source yields a higher quality of waste material for recycling.

WHY ORWAK FLEX?

- Versatile compaction for many different application areas
- Hygienic and safe compaction and disposal of mixed or hazardous waste
- Special solutions for special needs

 **ORWAK**[®]
PART OF *Sulo* GROUP

ORWAK FLEX 4240

Smart in-bin compaction solution

ORWAK FLEX 4240 is an in-bin waste compactor for standard two-wheeled 63 gal bins.

IDEAL FOR GENERAL WASTE

The 4240 is perfect for the hotel and restaurant sector, where general waste needs to be disposed of in waste bins. The in-bin compactor provides impressive volume reduction, contributing to valuable space-saving and a more profitable waste management.

SAFE AND USER-FRIENDLY

Model 4240 is user-friendly! The multi-chamber version is a convenient top-loading installation, while the single-chamber version has an easy wheel-in, wheel-out operation.

Safety and quality are our hallmarks and the compactor provides maximum personal safety both for the operator and those in the immediate vicinity. A bin indicator assures that the machine can only start, when the bin is in the right position.



Designed to fit the standard 63 gal bins in the market.

- User-friendly
- Safety switches on the hatch and the front door/apron

ORWAK FLEX 4240 IS OPTIMIZED FOR:

SEMI-DRY WASTE

- General waste

Best suited for dry or semi-dry waste destined for landfill or incineration

SMART DESIGN

The 4240 is a robust and stable machine that, thanks to its compact design, occupies little floor space. A good finish and easy access make cleaning quick and simple.

EASILY EXTENDABLE

The compactor is easily extended with additional chambers. The front door on the single-chamber unit is then replaced by an apron for effortless movement of the press head from one chamber to the next.



The single-chamber unit with swing door



The multiple-chamber unit equipped with an apron with two handles

DIMENSIONS & SPECIFICATIONS

DIMENSIONS				
A	B	C	D	TRANSPORT HEIGHT
Single: 7' 5"	Single: 29.5"	Single: 36.2"	Single: 59.6"	Single: 6' 11"
Double: 7' 5"	Double: 58.1"	Double: 39.0"		Double: 6' 11"

MACHINE WEIGHT		
TOTAL WEIGHT	PRESS UNIT	SINGLE STAND
Single: 485 lbs	265 lbs	220 lbs
Double: 705 lbs	265 lbs	

TECHNICAL SPECIFICATIONS					
BIN SIZE	CYCLE TIME	PRESS FORCE	NOISE LEVEL	PROTECTION CLASS	OPERATING POWER
63 gal	29 secs	3,300 lbs	62.3 db (A)	IP 55	Single phase 115 V, 60 Hz, 16 A

We reserve the right to make changes to specifications without prior notice. Bale/bag/bin weights are dependent upon material type.

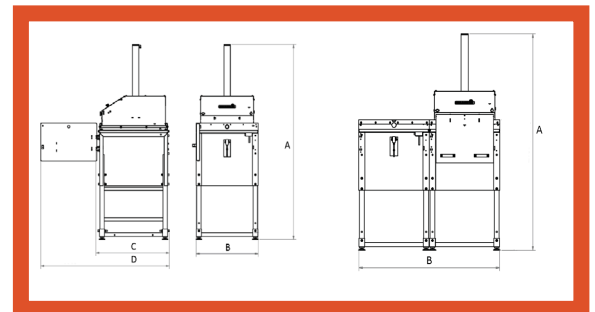

ORWAK NORTH AMERICA, INC.

9200 Globe Center Drive, Suite 130
Morrisville
NC 27560, USA
Phone: +1-800-747-0449
Email: info@orwakbalers.com

ORWAKBALERS.COM

ORWAK
PART OF **Sulo** GROUP