

ORWAK HORIZONTAL 2050 AT

The most compact baler in the range! This fully automated horizontal 10 ton baler provides effective compaction where space is very limited. Ideal for shredded paper and low volumes of cardboard! The baler produces compact and lightweight bales. It can be delivered in two parts for easier transportation on site. We provide well-proven technology for special demands! The automatic tying and the continuous baling enable multi-shift operation.

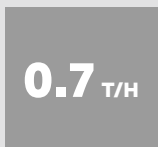

**AUTOMATIC
SOLUTION**



**CAPACITY
CARDBOARD**



**BALE WEIGHT
CARDBOARD**



ORWAK BENEFITS



MORE PRODUCTIVE USE OF TIME

Less time spent on waste handling, more time for your core activities!

MORE SPACE & ORDER

Our balers rapidly minimize the space the waste takes up, keeping aisles free and tidy.

LESS COSTS, MORE VALUE

More compaction = less waste volume to transport. Fewer transports required results in lower transportation costs and reduced CO₂ emissions. Sorting at source yields a higher quality of waste material for recycling.

WHY ORWAK HORIZONTAL?

- Effective large-scale waste handling
- Improved internal and external logistics
- Safe and comfortable working environment
- Excellent control over the throughput
- Increased income when delivering high-quality bales directly to the recycling industry.

ORWAK
PART OF SULO GROUP

ORWAK HORIZONTAL 2050 AT

Smart fully automated solution

COMPACT AND CLEVER DESIGN

The smallest baler in our HORIZONTAL line fits where you need it to be! On demand, it can be delivered in two parts for easier transportation to the installation site.

CONTINUOUS FEEDING AND OUTPUT

A completely automated waste management solution designed for continuous infeed, automatic horizontal or vertical strapping system with adjustable wire links, which enables you to yield optimal output.



OPTIMAL FEATURES

- Well proven technology
- Auto start (photocell) as standard
- High speed: fast throughput
- Adjustable bale length
- Vertical or horizontal automatic tying

HORIZONTAL 2050 AT IS OPTIMIZED FOR:

PAPER

- Paper sacks
- Shredded paper
- Cardboard

A VARIETY OF INFEED OPTIONS

To fit the conditions in your environment, our horizontal balers offer a wide choice of infeed systems: manual, by bin, air-transport and conveyor belt.

Our balers can also easily be equipped with shredders, bottle presses, rufflers, strippers and different types of hoppers.

OPTIONS

- Horizontal tying
- Bin lifter
- Conveyor belt
- Cooling and heating systems

More special options on demand

DIMENSIONS & SPECIFICATIONS

TECHNICAL SPECIFICATIONS

MACHINE DIMENSIONS (LXWXH) EXCL BALE EXIT	FEED OPENING	INFEED CAPACITY	PRESS FORCE	MOTOR	SURFACE PRESSURE	CYCLES PER MINUTE	CHANNEL SECTION	OIL TANK CAPACITY
4165x1060x2425 mm	450x800 mm	0.15 m ³	10 ton	7,5 kW/10 Hp	6 kg/cm ²	4	450x400 mm	80 L

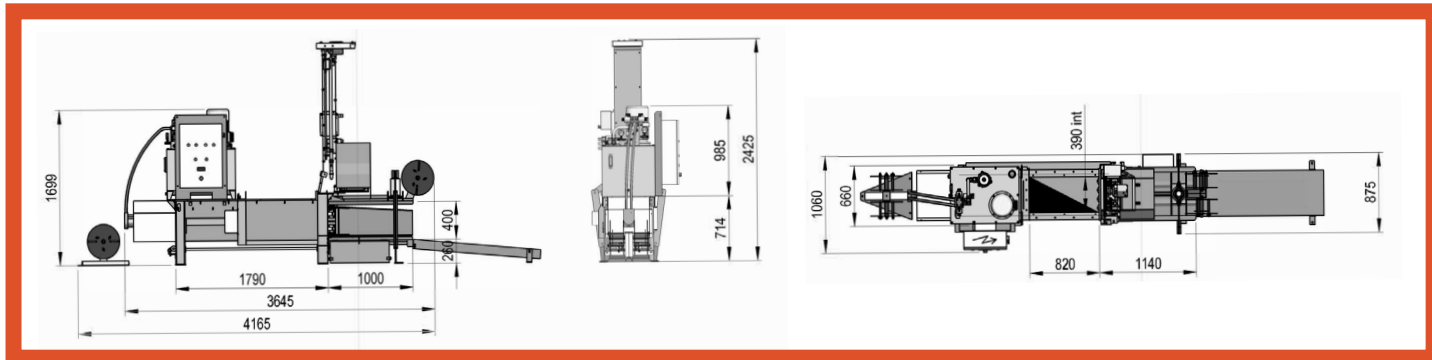

TECHNICAL SPECIFICATIONS

TOTAL MACHINE WEIGHT	THEORETICAL OUTPUT	LOADING OUTPUT	AUTOMATIC BINDING	BALE SIZE (ADJUSTABLE LENGTH)	BALE WEIGHT CARDBOARD <small>DEPENDS ON BALE LENGTH</small>
1150 kg	35 m ³ /h	21 m ³ /h	2 wires Ø 2.7	450x400x500-1000 mm	20-50 kg

We reserve the right to make changes to specifications without prior notice. Bale weights are dependent upon material type.

ORWAK AB

Svetsaregatan 4
S-576 33 Sävsjö
SWEDEN
Tel: +46-(0)382-15700
info@orwak.com

ORWAK.COM

ORWAK
PART OF JULO GROUP